



12V Voltage Regulator/Rectifier

www.pistonported.com

Basics:

Regulator: Regulates voltage produced by stator to 14.4V to prevent blowing bulbs and melting wires.

Rectifier: Converts (Rectifies) AC voltage produced by stator to DC voltage for battery

AC: Raw power produced by stator. Used in both battery and non-battery applications to power certain functions. For most intents and purposes consider AC power as the kind used on scooters not using a battery.

DC: Type of power used by batteries, which is why fitting a battery to a scooter requires a rectifier as stators only produce AC power.

Applications:

Our 12V regulator/rectifier can be used on either battery or non-battery models. The AC circuit needs to be bridged to function correctly (see wiring diagrams). If not using a battery, you can disregard the DC post on the Regulator/Rectifier.

Installation:

Installation requires an open-barrel crimping tool and knowledge of how to properly use it. We recommend practicing beforehand and watching videos on YouTube if you are unfamiliar.

We provide 5 female open-barrel spade connections, 2 complete open-barrel bullet connections and a factory-grade 250 series harness side regulator plug to complete installation.

The spade connectors lock into the supplied 250 series plug while the bullet connectors are supplied to use between any stator connections and the plug. This is important for future maintenance and repair as it ensures the engine can be easily disconnected from the wiring harness for removal.

Regulators/rectifiers require a solid ground connection and solid mounting to ensure long-lasting reliability and cooling efficiency.

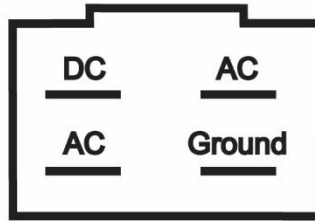

Basic Wiring

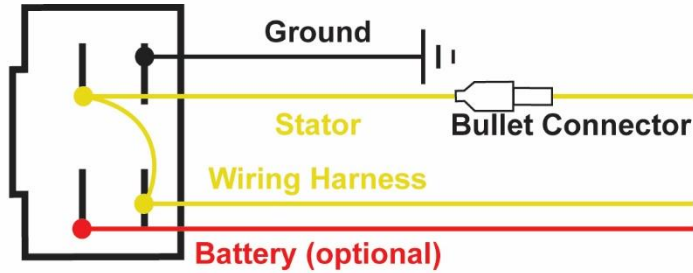

Varitronic/Casatronic/Vespatronic Wiring

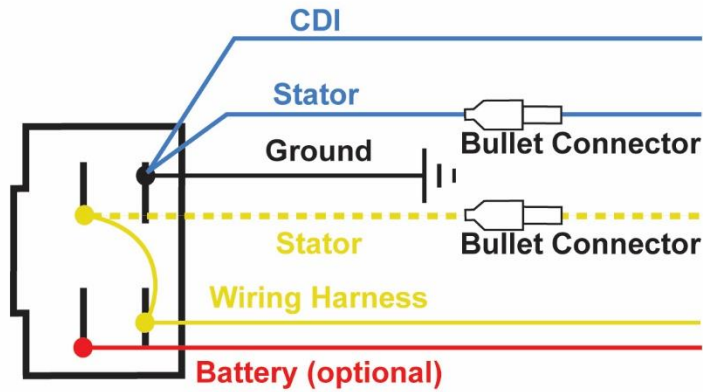

Vespa 3 Pin Regulator

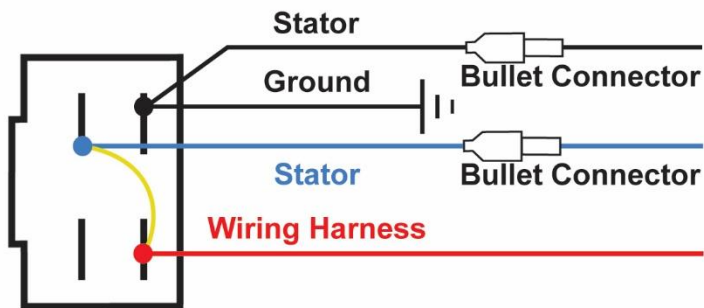

Vespa 5 Pin Regulator

